

REV	DESCRIPTION	BY	CHK	DATE	ECN
A	ENGINEERING RELEASE	CLL		1-6-95	MI2916

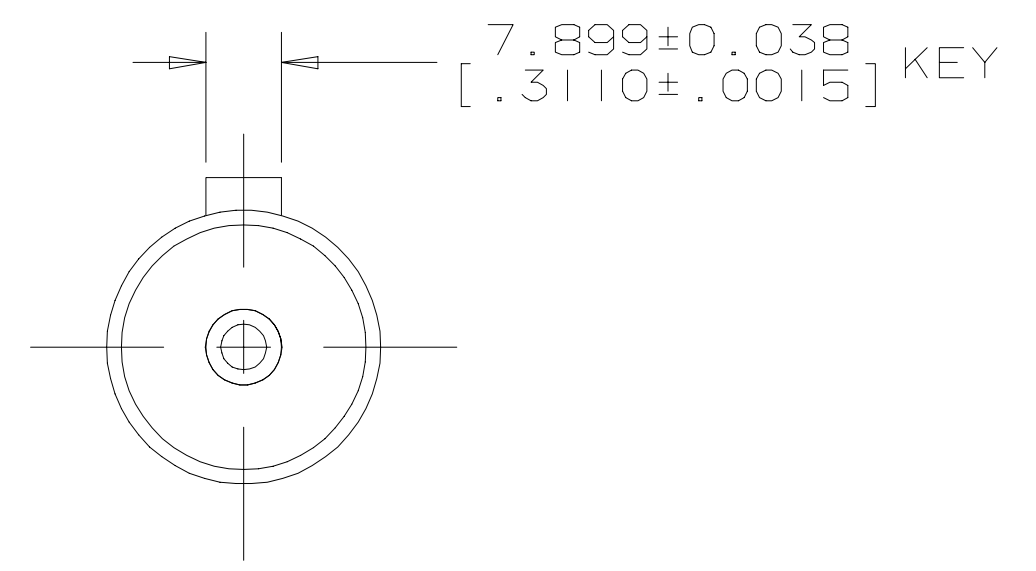

G H

UNLESS OTHERWISE SPECIFIED ALL DIMENSIONS ARE IN INCHES <input type="checkbox"/> MILLIMETERS <input checked="" type="checkbox"/> [INCHES]	DRAWING BASED ON ANSI Y14.5M-1982	
	THE REPRODUCTION, DISTRIBUTION, AND UTILIZATION OF THIS DOCUMENT, AS WELL AS THE COMMUNICATION OF ITS CONTENTS TO OTHERS WITHOUT EXPLICIT AUTHORIZATION IS PROHIBITED. OFFENDERS WILL BE HELD LIABLE FOR THE PAYMENT OF DAMAGES. ALL RIGHTS RESERVED IN THE EVENT OF THE GRANT OF A PATENT, UTILITY MODEL, OR DESIGN. (PER ISO 16016)	
TOLERANCES .X ± --- .XX ± REF .XXX ± ONLY < ± ---	DRAWN BY/DATE CLL 2-3-95 CHECKED BY/DATE ENGRG BY/DATE METALLURGY BY/DATE ---	MATERIAL/HEAT TREAT TITLE SHAFT INSTALLATION
UNSPECIFIED RADII ARE --- UNSPECIFIED DRAFT ANGLES ARE ---	THIRD ANGLE PROJECTION DO NOT SCALE	MICROINCHES <input type="checkbox"/> MICROMETERS <input type="checkbox"/> [MICROINCHES] ARITHMETICAL AVERAGE <input checked="" type="checkbox"/>
DRAWING FORMAT CADD <input checked="" type="checkbox"/> MANUAL <input type="checkbox"/>	NUMBER A-290-083 SCALE 1/1 SHEET 1 OF 1	

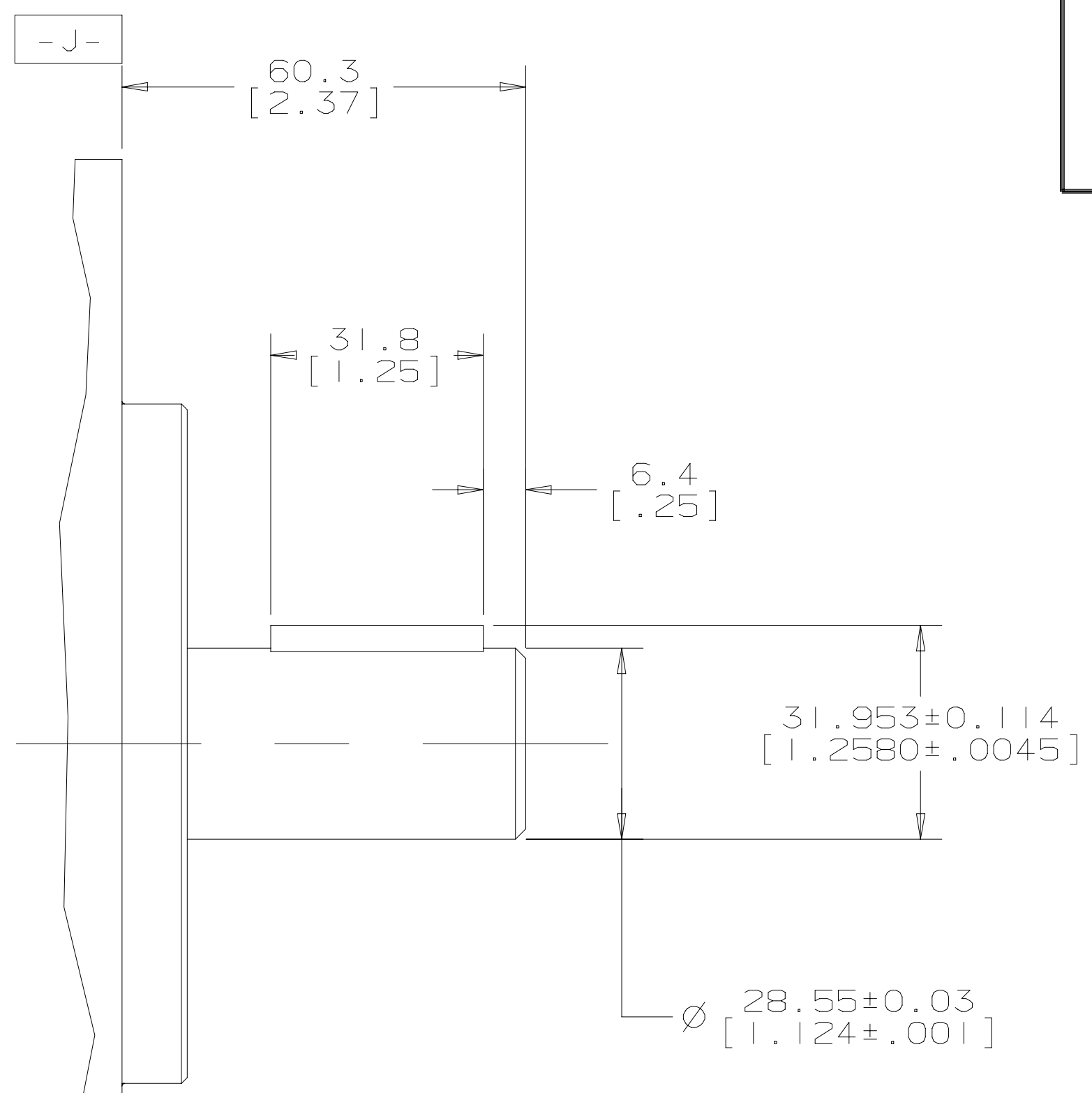