

REVISIONS			
REV	DESCRIPTION	DATE	APPROVED
E	REDRAWN-SUPERSEDES 1SA_FRA_SHEET 3 REV."D" FOR 1SA8FRA8	10-31-95	EN-F16050 DP-24900
F	1) FINISH WAS "ZINC PLATE PER ACES 2751".	2020-07-24 PAI	CO-0206323

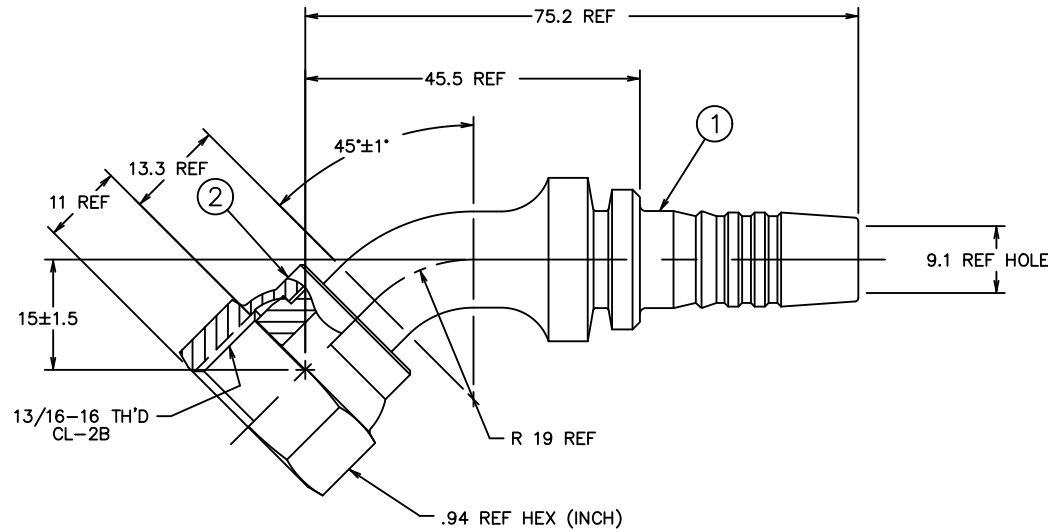

75.2	2.96
45.5	1.79
19	.75
15±1.5	.59±.06
13.3	.52
11	.43
9.1	.36
MM	INCH

CONVERSION

METRIC

1. PROCESS AS FOLLOWS:
 (a) BEND NIPPLE TO DIMENSIONS SHOWN.
 (b) ZINC PLATE PER ES 2751D8.
 (c) CRIMP NUT PER ACES 2409P1.

F 1

1SA8FRA8	1F40022-0808AB	FC1473-08S			
AEROQUIP PART NUMBER	① NIPPLE	② NUT			
LIST OF MATERIALS					
ITEM NO.	MATERIAL	DRAWN R.D.GARRETT	FLUID CONVEYANCE DIVISION DRAWING TITLE NIPPLE ASSEMBLY 45°, ORS FEMALE SWIVEL, 2781 HOSE SIZE A2 DRAWING NUMBER 1SA8FRA8 REV F SCALE 2/1 DIST U CAGE CODE 01276 SHEET		
1	STEEL	CHECKED M. MOLINA			
2	STEEL	APPROVED R.D.GARRETT			
		RELEASE DATE 11-1-95			
		EN-F16050 DP-24900			
THIRD ANGLE PROJECTION					
THE REPRODUCTION, DISTRIBUTION AND UTILIZATION OF THIS DOCUMENT AS WELL AS THE COMMUNICATION OF ITS CONTENTS TO OTHERS WITHOUT EXPLICIT AUTHORIZATION IS PROHIBITED. OFFENDERS WILL BE HELD LIABLE FOR THE PAYMENT OF DAMAGES. ALL RIGHT RESERVED IN THE EVENT OF THE GRANT OF A PATENT, UTILITY MODEL OR DESIGN. (PER ISO 18016)					