

REVISIONS			
REV	DESCRIPTION	DATE	APPROVED
G	(1) ADDED INCH DIMENSIONS AND NOTE #4. (2) ADDED ALTERNATE CONSTRUCTION, NOTE #5.	2002-10-16  W.R.H./B.A.T.	EN-F22890 DP-1299

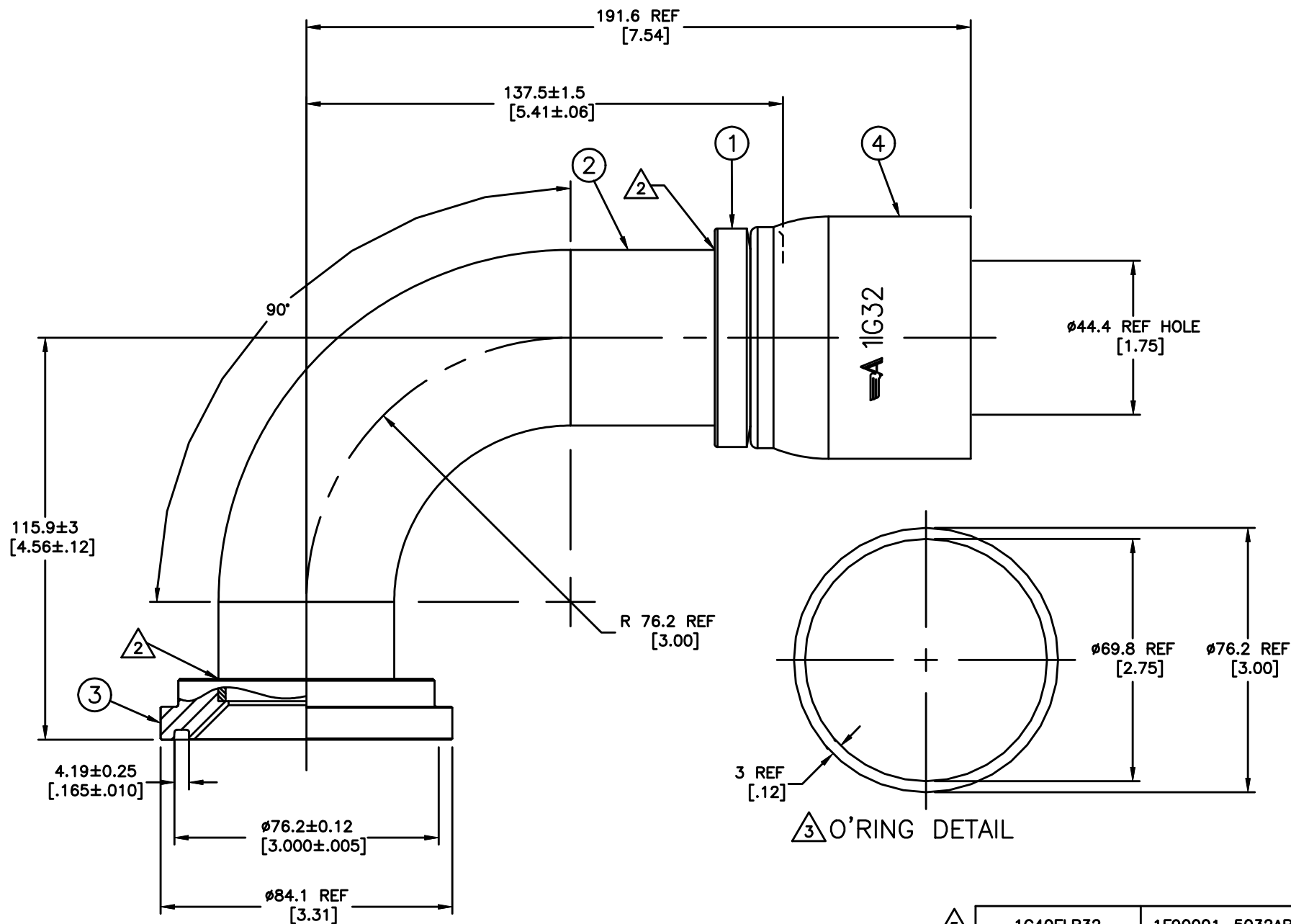

- 6. 1S40FLB32 NIPPLE ASSEMBLY MAY BE SUBSTITUTED FOR ITEMS #1, #2 & #3.
- 5. ALTERNATIVE CONSTRUCTION. (2)
- 4. DIMENSIONS ARE IN MILLIMETERS [INCHES]. (G)
- 3. O-RING SHOWN FOR REFERENCE ONLY: SUPPLIED BUT NOT FURNISHED WITH ASSEMBLY.
- 2. BRAZE PER ACES 2814.
- 1. ZINC PLATE PER ACES 2751.

5	1G40FLB32	1F90001-5032AR	19.020-50.2	17.007-50-40	1G32	
	1G40FLB32	1F40014-3232AB	1F40034-32-01AB	4624-40-32S	1G32	
	AEROQUIP PART NUMBER	(1) NIPPLE	(2) ELBOW	(3) SHOULDER	(4) SOCKET	

LIST OF MATERIALS

ITEM NO.	MATERIAL
1	STEEL
2	STEEL
3	STEEL
4	STEEL

DRAWN W.R.HYDE CHECKED B.A.THOMAS APPROVED B.A.THOMAS RELEASE DATE 2002-10-16 EN-F22890 DP-1299 THIRD ANGLE PROJECTION	FLUID CONVEYANCE DIVISION DRAWING TITLE <b>NIPPLE ASSEMBLY</b> 90°, SPLIT FLANGE TYPE (CODE 61), OTC
SIZE A2	DRAWING NUMBER 1G40FLB32
SCALE 1/1	DIST U
CAGE CODE 01276	SHEET
THE REPRODUCTION, DISTRIBUTION AND UTILIZATION OF THIS DOCUMENT, AS WELL AS THE COMMUNICATION OF ITS CONTENTS TO OTHERS WITHOUT EXPLICIT AUTHORIZATION IS PROHIBITED. OFFENDERS WILL BE HELD LIABLE FOR THE PAYMENT OF DAMAGES. ALL RIGHTS RESERVED IN THE EVENT OF THE GRANT OF A PATENT, UTILITY MODEL OR DESIGN. (PER ISO 16016)	

REV. G  
 SH.  
 1G40FLB32  
 DWG. NO.