

SYM	REVISION	BY	DATE	ECN
A	ENGINEERING RELEASE	RLL	11-10-87	14736
B	1.106±.008 WAS ±.005 28,09±0,20 WAS ±0,13	LE	2-15-88	15101
C	.250-20 UNC-2B X .40/10,2 MIN DP WAS .250-20 UNC-2B X .56/14,2 MIN DP	RAF	6-14-94	25640

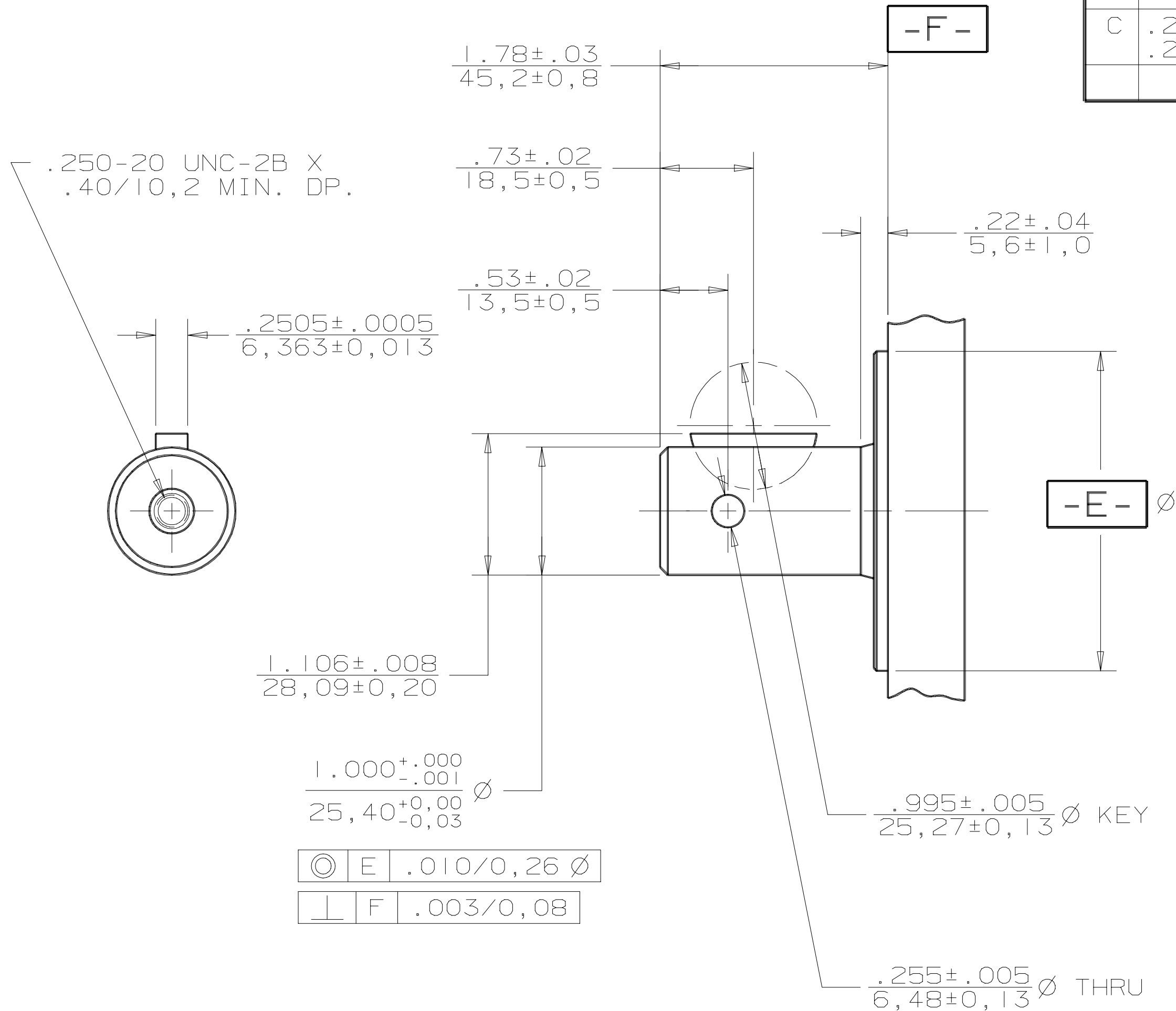

MODEL NO.
MOXXXX06XXXXXXX

SMG²

◎ | E | .010/0,26 ∅
└ | F | .003/0,08

THE REPRODUCTION, DISTRIBUTION, AND UTILIZATION OF THIS DOCUMENT, AS WELL AS THE COMMUNICATION OF ITS CONTENTS TO OTHERS WITHOUT EXPLICIT AUTHORIZATION IS PROHIBITED. OFFENDERS WILL BE HELD LIABLE FOR THE PAYMENT OF DAMAGES. ALL RIGHTS RESERVED IN THE EVENT OF THE GRANT OF A PATENT, UTILITY MODEL, OR DESIGN. (PER ISO 16016)			
DRAWN BY/DATE RLL 10-28-87	MATERIAL/HEAT TREAT		
CHECKED BY/DATE KO 1-13-88	TITLE SHAFT INSTALLATION		
ENGRG BY/DATE WCW 1-19-88	DO NOT SCALE		
THIRD ANGLE PROJECTION	LINEAR MEASUREMENT IN/MM IN/MM	NUMBER A-109-006	
SCALE FULL SIZE		SHEET 1 OF 1	

OUTPUT SHAFT
 06 = 1.00/25,4 DIA. STRAIGHT WITH WOODRUFF KEY,
 .25/6,4 DIA. CROSSHOLE .53/13,5 FROM END,
 AND .250-20 THREADED HOLE